

Relay7™

Seven power relays and seven high voltage drivers for industrial applications



Technical Manual



1950 5th Street, Davis, CA 95616, USA

Tel: 530-758-0180

Fax: 530-758-0181

Email: sales@tern.com

<http://www.tern.com>

© TERN, Inc. All Rights Reserved.

COPYRIGHT

Relay7, A-Engine, A-Core, and V25-Engine are trademarks of TERN, Inc.

Version 2.00

November 2, 2010

No part of this document may be copied or reproduced in any form or by any means without the prior written consent of TERN, Inc.

© 1998-2010 
1950 5th Street, Davis, CA 95616, USA
Tel: 530-758-0180 Fax: 530-758-0181
Email: sales@tern.com <http://www.tern.com>

Important Notice

TERN is developing complex, high technology integration systems. These systems are integrated with software and hardware that are not 100% defect free. ***TERN products are not designed, intended, authorized, or warranted to be suitable for use in life-support applications, devices, or systems, or in other critical applications.*** ***TERN*** and the Buyer agree that ***TERN*** will not be liable for incidental or consequential damages arising from the use of ***TERN*** products. It is the Buyer's responsibility to protect life and property against incidental failure.

TERN reserves the right to make changes and improvements to its products without providing notice.

Temperature readings for controllers are based on the results of limited sample tests; they are provided for design reference use only.

Chapter 1: Introduction

1.1 Functional Description

In many industrial applications, 12V or 24V control signals are required; however, most embedded controllers provide TTL level (0-5V) input or output only. The Relay7 (R7) board is designed to support signal conversion of high voltage (up to 30V) digital signals and TTL level digital signals.

The Relay7 offers seven power relays. Each power relay provides Normal Close, Normal Open, and COM contacts, rated at 5A or more @ 35V. Seven red LED indicators are installed to indicate the power relay status. The user may install MOVs to protect relay contacts.

An additional seven I/O channels with high voltage drivers are also on board. These seven high voltage I/O channels are hardware-configurable as 0V to 30V inputs or as 0V to 30V outputs at the screw terminals, T1.

1.2 Features

- Dimensions: 4.4 x 2.2 x 0.8 inches
- Power supply input voltage: +12 V unregulated DC
- Seven mechanical power relays with Normal Open, Normal Close, and Common contacts rated at least 5A @ 250V.
- Seven channels of high voltage (0V to 30V) inputs or outputs.

A functional block diagram of the Relay7 is shown below in Figure 1.1.

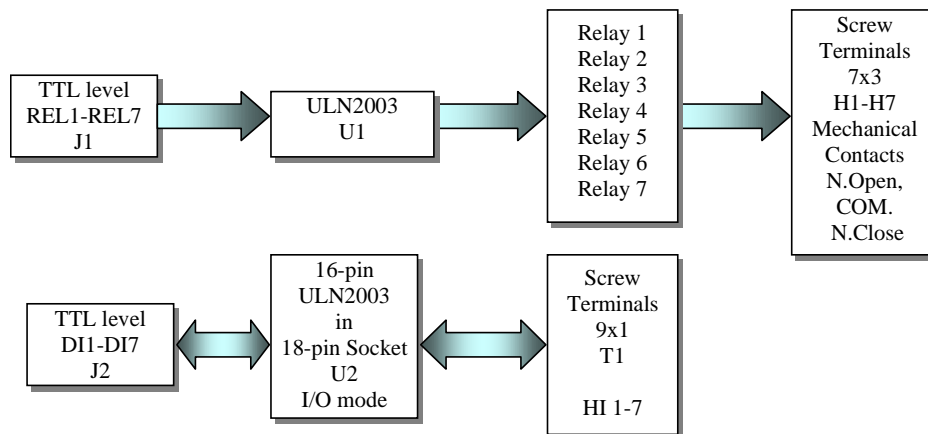

Figure 1.1 Relay7 functional block diagram

1.3 Physical Description

Figure 1.2 shows the physical layout of the Relay7. Dimensions are given in inches.

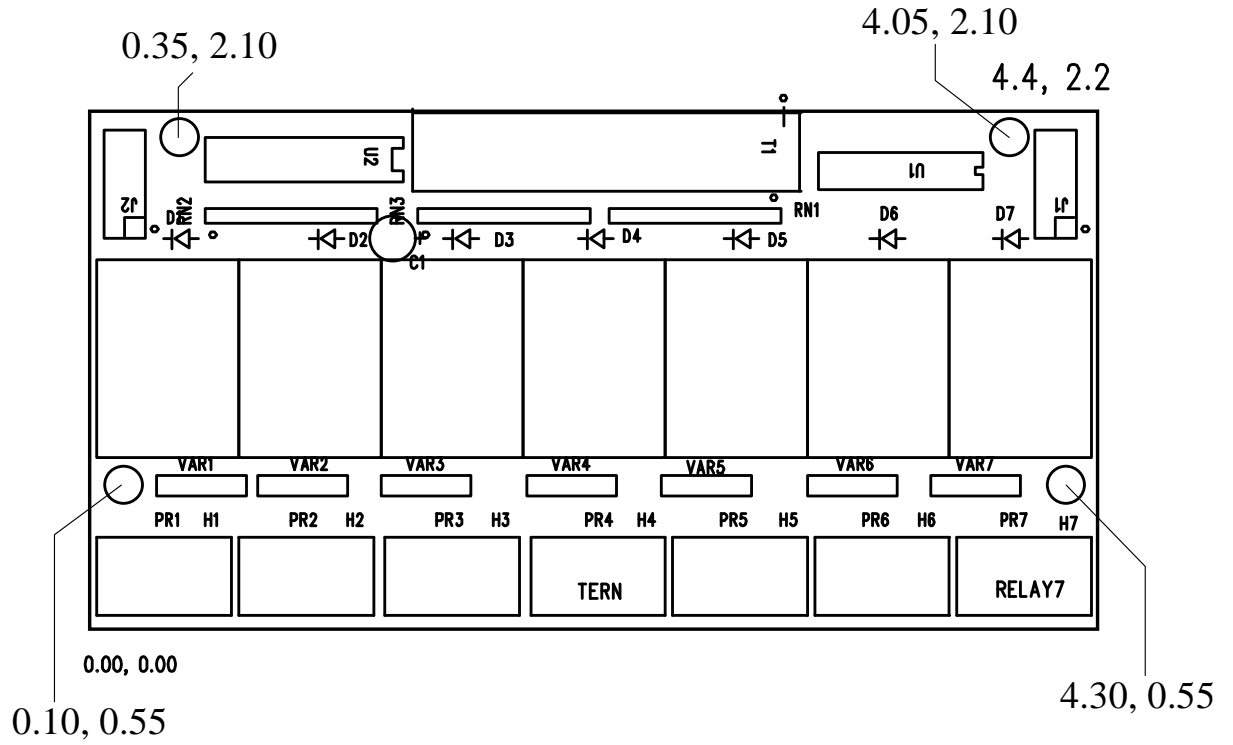

Figure 1.2 Layout of the Relay7

Chapter 2: Hardware

For many industrial applications, contact switch signals need to be 12V or 24V. In order to be useful, a control signal may have to drive a solenoid coil or a mechanical relay at 12V or 24V DC.

Most microcontrollers provide TTL-level digital control signals only. The Relay7 is designed to provide a buffer interface between TTL digital signals and the industrial control environment.

The ULN2003 is a high voltage, high current Darlington transistor array, consisting of seven silicon NPN Darlington pairs on a common monolithic substrate. All channels feature open-collector outputs for sinking 350 mA at 50V, and integral protection diodes for driving inductive loads. Peak inrush currents of up to 600 mA sinking are allowed. The outputs may be paralleled to achieve high-load capability, although each driver has a maximum continuous collector current rating of 350 mA at 50V. The maximum power dissipation allowed is 2.20 W per chip at 25 degrees Celsius (°C).

The common substrate G is routed to GND. All currents sinking in return through the J2 GND pin. A heavy gauge (20) wire must be used to connect the T1 GND pin to the external power supply ground return.

K provides a connection to the protection diodes. K should be tied to the highest voltage in the external load system. It is connected to +12V at U2 pin 1 and T1 pin 9. ULN2003 is a sinking driver, not a sourcing driver.

Please refer to the Relay7 schematic “RELAY7.SCH” (found at the end of this manual) for the following discussion.

2.1 Power Relays

The Relay7 provides seven mechanical power relays. The Normal Open, Normal Close, and Common pins of each power relay are connected to the terminal blocks (T1) with heavy traces that support at least 5A current. The relays are driven by seven solenoid drivers (U1, ULN2003) that are controlled by seven TTL control signals, REL1-7. They are routed to a 5x2-pin dual row pin header, J1. The user can drive a relay via the J1 header with an input voltage of 0V to turn the relay off, or a positive voltage ranging from +3V to +30V to turn the relay on.

For mechanical relay contact protection, you may install MOVs on the pads labeled “VARx”.

2.2 High-voltage I/Os

An additional seven high voltage drivers are installed in the U2 socket to provide seven high voltage inputs or outputs.

The 16-pin ULN2003 chip is installed in the 18-pin U2 socket. This allows you to configure the chip to operate in either input mode or output mode.

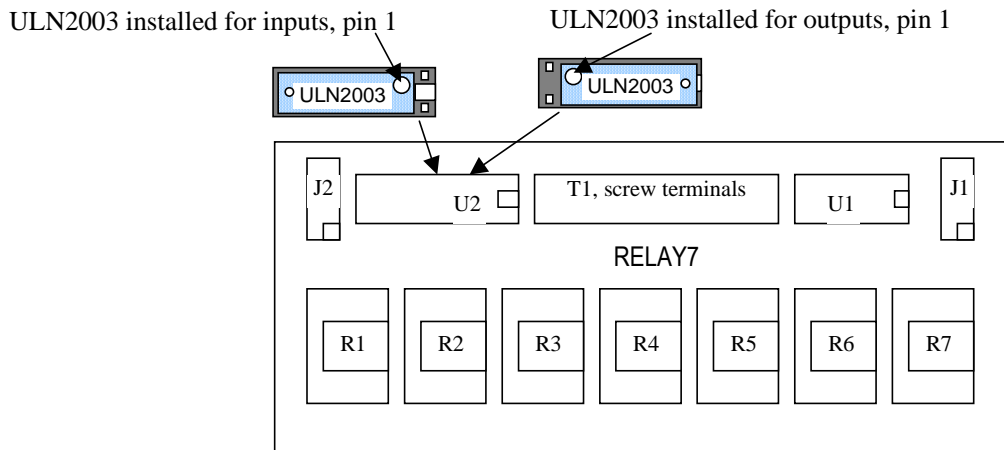

Figure 2.1 Installation of user-configurable Darlington Transistor Array in U2.

The ULN2003 is installed as a solenoid driver output by factory default. When the ULN2003 is installed as a solenoid driver output, pins 1 to 8 of the chip are next to the power relays, and the other side of the chip (pins 9 to 16) is next to the outside edge of the board, leaving pins 9 and 10 of the socket empty.

For using the ULN2003 as output, see Figure 2.2.

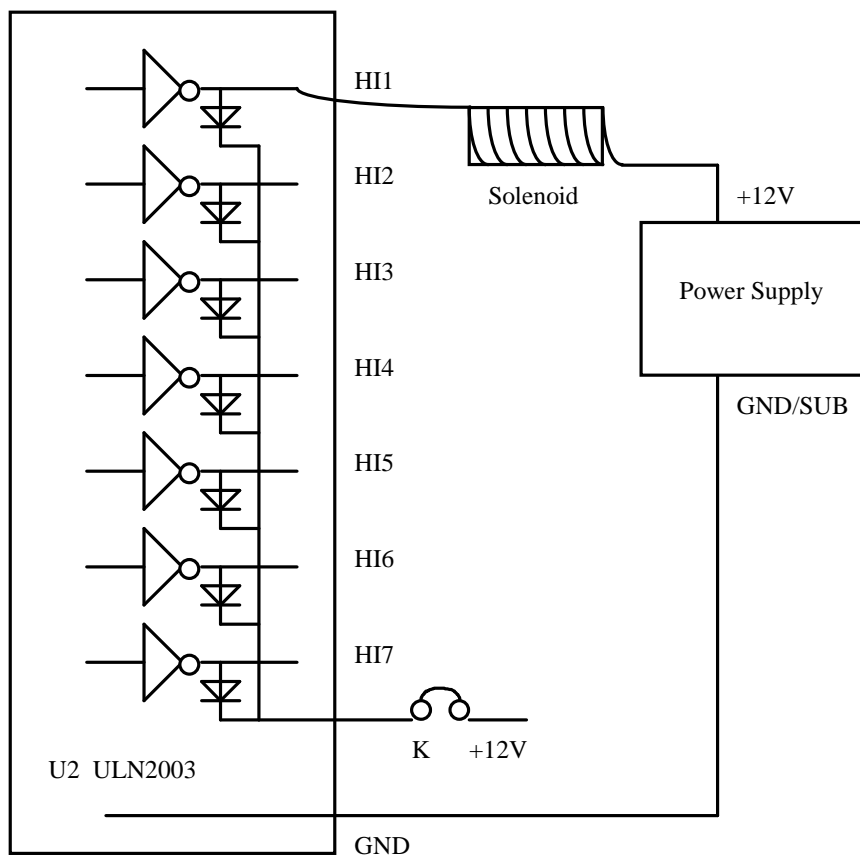

Figure 2.2 Using ULN2003 as output: drive inductive load with high voltage/current drivers

If you wish to use high voltage inputs, you must take the ULN2003 chip out of the socket, turn it 180 degrees, and line it up in the U2 socket with pins 9 and 10, thus leaving pins 1 and 18 of the U2 socket empty.

The maximum input voltage is 30V. You may install a pull-up resistor network in RN3. A valid input low voltage is less than 0.8V, and the input high voltage must be higher than 3V and less than 30V.

For using ULN2003 as input, see Figure 2.3.

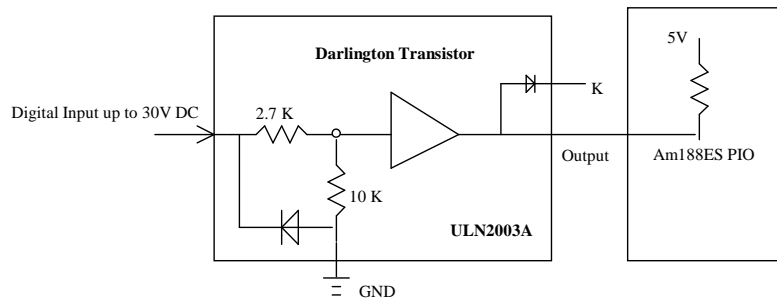
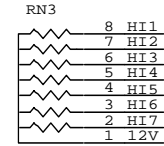
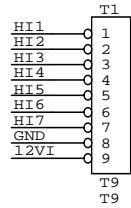
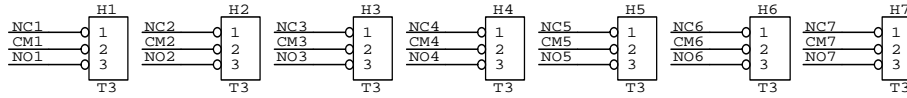
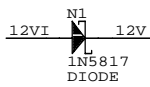
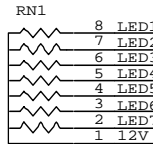
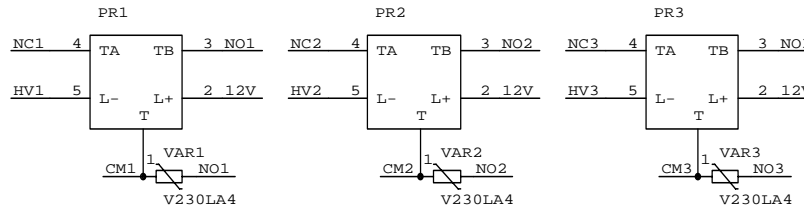
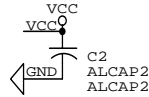
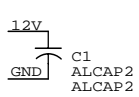

Figure 2.3 Darlington Transistors can be used as Protective High Voltage Inputs.



10K
RN8S1



4.7K
RN8S1

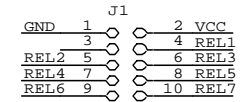
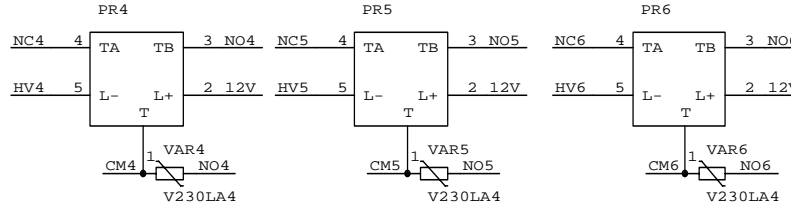

HDRD10

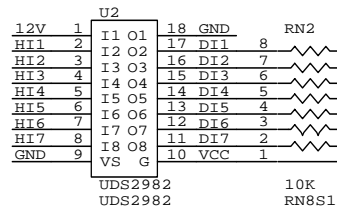
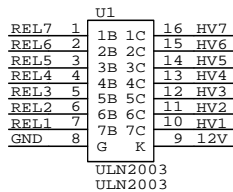
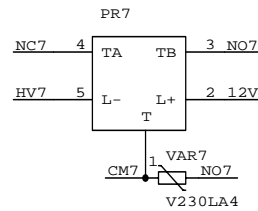
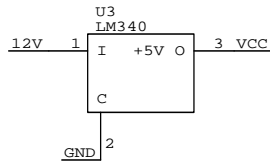
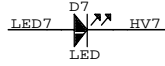
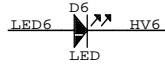
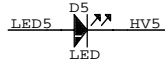
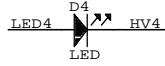
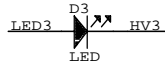
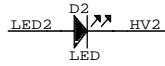
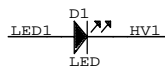

UDS2982 10K
UDS2982 RN8S1

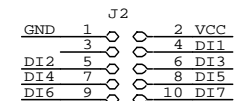

HDRD10

STE/TERN, INC.		
Title		
7 POWER RELAYS		
Size	Document Number	REV
B	RELAY7.SCH	
Date:	August 10, 1999	Sheet of